







Isotop DSD

Steel spring isolators with integrated high-performance dampers

- Natural frequency from 4.2Hz
- Sylodamp[®] inside - ideal for machines with several start-stop cycles
- Cathodic dip-coating (CDC) for increased corrosion protection
- Secure connection between the plate and the spring thanks to special adhesive
- M10 internal thread
- Suitable base plate and/or height adjustment available
- Base plate with damping element (FP/K) also isolates higher frequencies
- Simple load control thanks to open design
- Spring design conforms to DIN EN 13906-1

		Maximum load		Natural frequency at maximum load	Packaging unit	Order number
		in kg	in N			
DSD spring element KTL 	Isotop DSD 1 KTL	24	235	5.6 Hz	50 pcs.	39492
	Isotop DSD 2 KTL	39	383	4.9 Hz	50 pcs.	39493
	Isotop DSD 3 KTL	57	559	4.8 Hz	50 pcs.	39495
	Isotop DSD 4 KTL	87	853	4.2 Hz	50 pcs.	39496
	Isotop DSD 5 KTL	140	1,373	4.8 Hz	50 pcs.	39497
	Isotop DSD 6 KTL	200	1,962	4.3 Hz	50 pcs.	39157
	Isotop DSD 7 KTL	365	3,581	5.2 Hz	50 pcs.	39498
	Isotop DSD 8 KTL	470	4,611	4.7 Hz	50 pcs.	39499
	Isotop DSD 9 KTL	650	6,377	4.6 Hz	50 pcs.	39500
Base plate FP/K with damping element for SD/DSD 	Isotop FP/K 1-9 KTL		for DSD 1 to 9	including screws ¹	50 pcs.	39158
Base plate FP for SD/DSD 	Isotop FP 1-9 KTL		for DSD 1 to 9	without screws	50 pcs.	39537
Height adjustment for SD/DSD 	Isotop NV 1-9	M10	for DSD 1 to 9		50 pcs.	47321

¹ M10 connecting screws between base plate and spring

Isotop SD (unloaded)

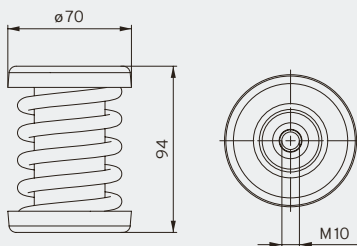

Isotop FP/K

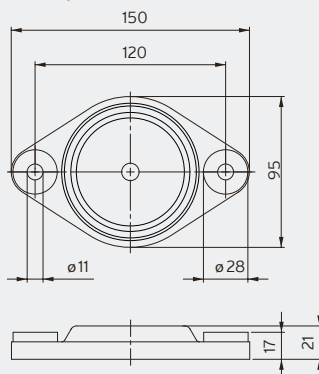

Isotop FP

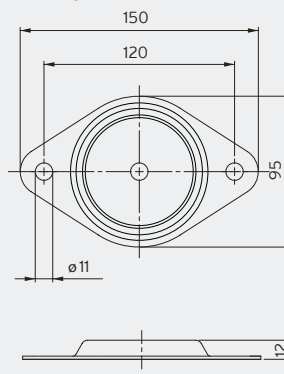

Isotop NV 1-9

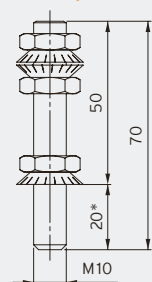

*Thread reach SD/DSD



Small combined heat and power plant



Roof-mounted recoler

Isotop DSD 1

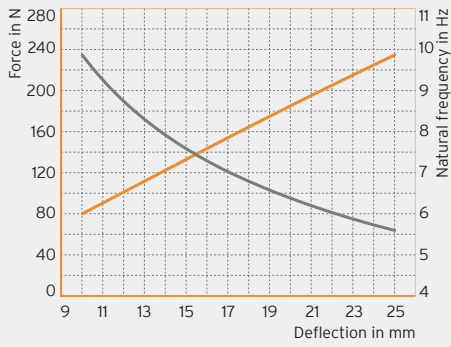

Isotop DSD 2

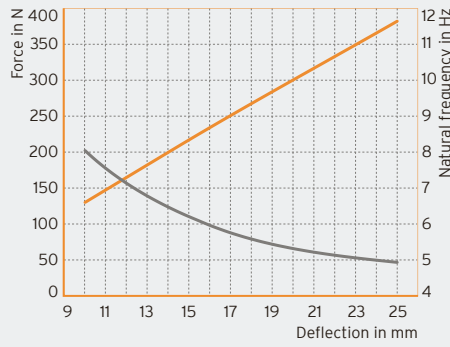

Isotop DSD 3

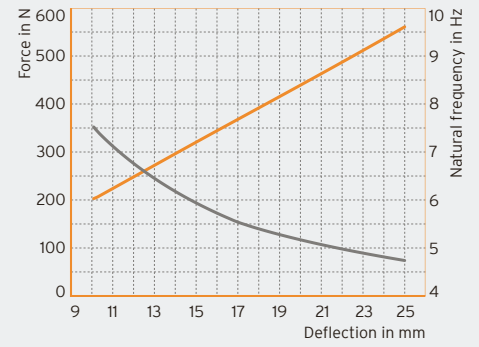

Isotop DSD 4

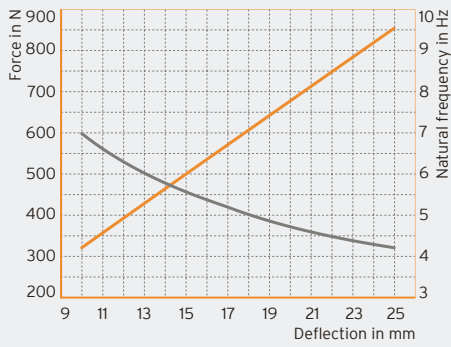

Isotop DSD 5

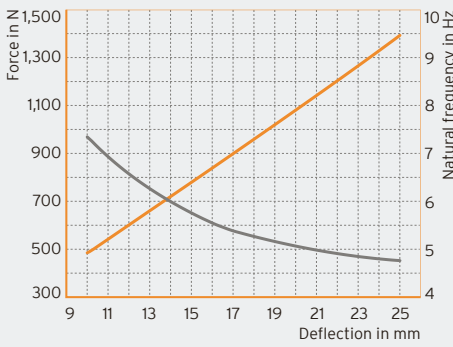

Isotop DSD 6

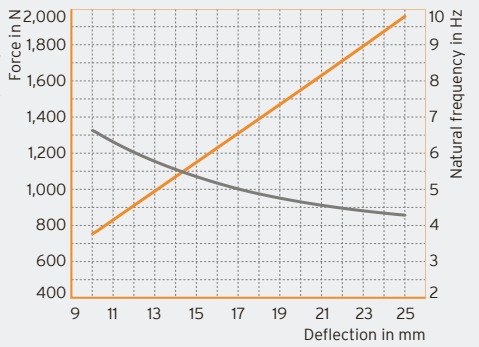

Isotop DSD 7

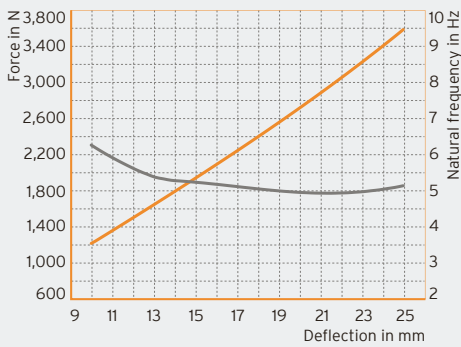

Isotop DSD 8

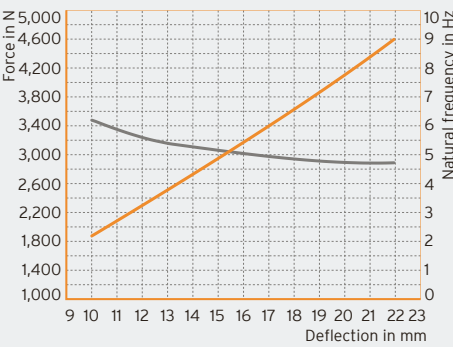

Isotop DSD 9

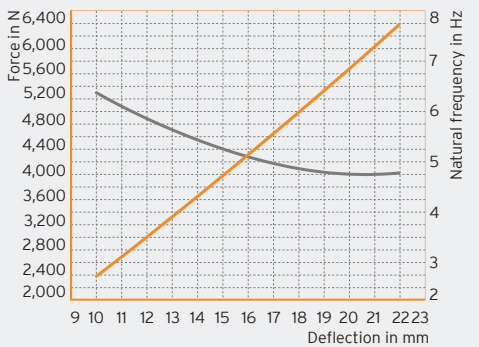

— Force in N
— Natural frequency in Hz

DB Isotop en © Copyright by Getzner Werkstoffe GmbH | 09-2022 | All information and data is based on our current knowledge. It can be used in calculations and for reference purposes, but is subject to product-specific and application-specific manufacturing tolerances and does not represent warranted properties. Material properties and their tolerances vary depending on the type of application and load and are available from Getzner on request. Subject to change without notice. For further general information, see VDI directive 2062 and glossary. Further characteristic values available on request.