

Code of Conduct

1. The Importance of the Code of Conduct in the Management's View

Getzner Werkstoffe GmbH with its affiliated companies (hereinafter 'Getzner') is known for vibration protection and is considered worldwide as a reliable partner.

Since 1969 Getzner has been offering solutions for damping and insulating vibrations and structure-borne noise. The high-tech materials Sylomer®, Syldyn® and Sylo-damp® originate from the own research and are used in the railway, construction and industrial sectors. They reduce vibrations and noise, extend the service life of the stocked components and thus reduce the maintenance and servicing costs of rail infrastructure, vehicles, construction works and machines. Getzner applications reduce environmental impacts such as noise and vibration and reduce the CO₂-footprint in the overall system.

In addition to the company's own locations and branches, Getzner materials are also distributed through selected partners all over the world. Getzner thus valuably contribute to increasing the life quality.

Getzner is committed to sustainable, economic action and to protecting environment and resources. However, compliance with ethical, social and legal concerns is equally important for Getzner. In this context, this Code of Conduct shows all employees, managers and partners the way to combine the corporate philosophy with sustainable competitiveness.

Bürs, November 2023

Jürgen Rainalter

Managing Director Getzner Werkstoffe GmbH

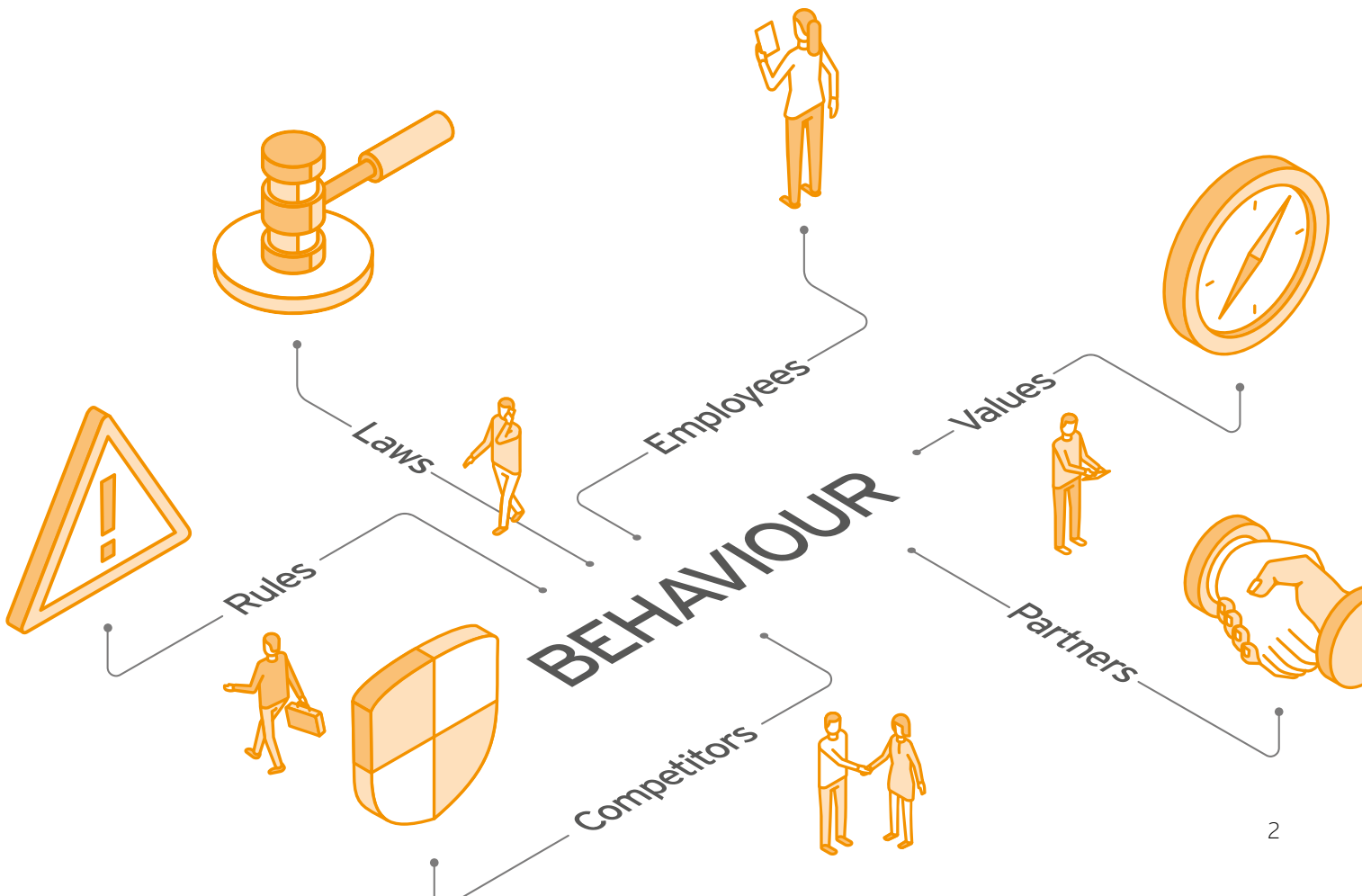

2. Subject Matter of the Code of Conduct

This Code of Conduct sets out the principles applicable to all of Getzner's activities.

Getzner offers sustainable solutions for sustainable protection against vibrations and noise, in particular to improve the life quality.

The conduct towards employees, partners and competitors results from this mission and the ethical and social values anchored in the company. This Code of Conduct defines the standard for sustainability, integrity and correct behaviour in the business environment. It is specifically based on the principles of the UN Global Compact and the 17 Sustainable Development Goals (SDGs), and is addressed not only to employees and managers (including lessees), but also to all consultants, agents, representatives, sales partners and all other persons working for Getzner (hereinafter referred to as 'Partners'). For suppliers, there is also the Supplier Code of Conduct, specifying Getzner's expectations vis-à-vis the suppliers.

This Code of Conduct is binding for all employees at all Getzner locations. New employees are immediately obliged to comply with the Code of Conduct in their employment contract. Irrespective of this, all employees are personally

responsible for compliance with and implementation of the Code of Conduct at all times. Managers support employees in implementing the Code of Conduct and model behaviour with integrity. Their conduct shall always be in accordance with the regulations of the Code of Conduct. In addition, they also instruct their employees in dealing with the Code of Conduct, they monitor compliance and provide training with the support of the competent bodies.

The Code of Conduct's provisions shall apply mutatis mutandis to Getzner's Partners (unless otherwise stipulated) and shall be fully complied with by them. Getzner shall also ensure that its Partners accordingly comply with the regulations of this Code of Conduct in their activities for / with Getzner.

Getzner always complies with applicable local and international law. Should mandatory local law be stricter than the regulations of this Code of Conduct, then such stricter provisions shall prevail. In the presence of such statutory provisions, there is no discretion. The Code of Conduct is thus understood as the "minimum standard". Employees are expected to approach every situation with reason and integrity so that the standards of this Code of Conduct are always upheld and maintained. In the event of ambiguities or questions, the direct supervisors are available to provide advice and help with decisions. Partners may also contact their contact person at Getzner or the compliance officers directly, at any time, should they have questions about the Code of Conduct.

The compliance body in charge is the highest authority for the binding interpretation of the Code of Conduct regarding questions of interpretation and also disputes.

The Code of Conduct is updated by Getzner's management as required and, if necessary, supplemented by more specific policies, which may also apply exclusively to certain countries or regions.

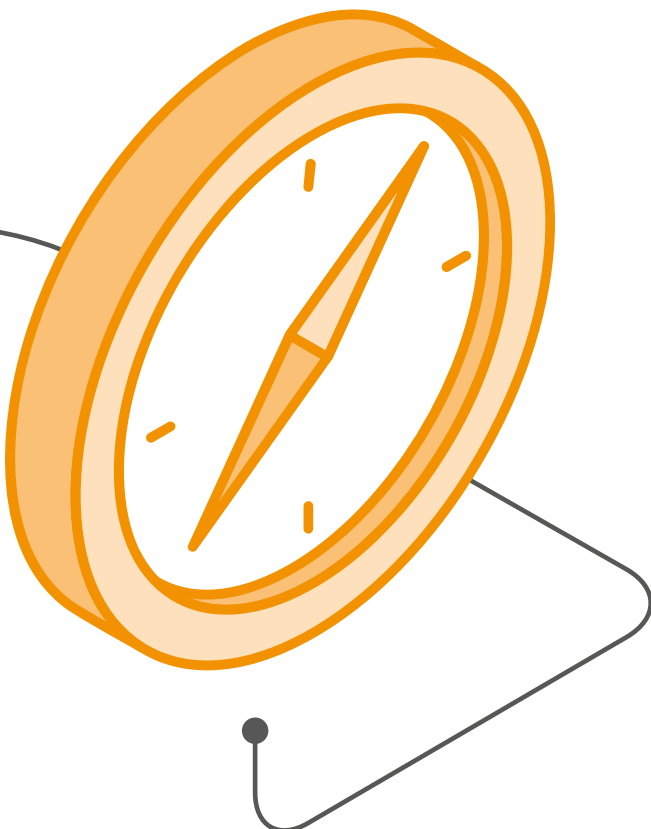

3. Ethical and Social Values at Getzner

Ethical and social values guide, worldwide, Getzner's daily actions.

Human rights and discrimination

The nationally and internationally recognised human rights, in particular the UN Declaration of Human Rights, as well as the associated respect for human dignity are central elements of this Code of Conduct, which shall be observed and complied with accordingly by all employees and Partners. Getzner is committed to the equal treatment of all persons - regardless of age, gender, religion, sexual orientation, ethnic or national origin, political opinion, physical or mental disability. Getzner treats all employees equally, does not tolerate any form of discrimination and promotes equal opportunities.

Respectful treatment

Getzner deems important that all its employees are always valued and respected - both in internal and external cooperation. Every cooperation should be characterised by decency, mutual respect, fairness and trust. Condescending, humiliating, insulting or otherwise disrespectful behaviour, especially towards colleagues, shall not be tolerated in any form.

Right to association and opinion

The right of employees and Partners to associate and the related opportunity to engage in trade union activities is respected accordingly by Getzner at all locations worldwide. In particular, the right to freedom of opinion and expression is protected as long as it does not cause harassment to other employees, Partners and competitors.

Child and forced labour

Getzner categorically rejects any and all forms of child or forced labour (including modern slavery and human trafficking). Getzner expects the same from its Partners.

Remuneration

All relevant laws and regulations are observed within regard to remuneration. This is especially true about the level of remuneration. Getzner shall recognise the right to fair remuneration for all employees.

Protection from harassment

Any kind of psychological, physical or sexual harassment is prohibited.

Health and safety

Getzner shall ensure that all relevant statutory health and safety provisions are properly implemented in the company's own operations. As an integral part of all operational processes, occupational safety and health protection are included in all technical, economic and social considerations from the very beginning.

All employees are obliged to support all measures serving occupational safety, to follow instructions for the purpose of accident prevention - in particular all safety precautions - and to use the personal protective equipment provided (e.g. protective clothing, safety shoes, safety glasses, hearing protectors). All employees shall pay constant attention to occupational safety.

Getzner also requires its Partners to respect and comply with the relevant health and safety regulations for their employees.

Environment

Getzner gives great importance to sustainable environmental and climate protection and expects the same from Partners. Therefore, compliance with all laws and regulations as well as internationally recognised standards for the environment protection is of great significance to Getzner; the safe and environmentally compatible development (incl. circularity), production, transport, use and disposal of products are promoted accordingly. When operating production facilities, Getzner shall also ensure that the outgoing impact on the environment and climate is kept as low as possible.

Resources are used efficiently and sparingly, energy-efficient and environmentally friendly technologies are used and waste quantities as well as emissions to air, water and soil are steadily reducing.

Proper management systems ensure that product quality and safety meet the applicable requirements.

Education and training

Getzner supports and promotes the professional education and training of its employees in order to prepare them in the best possible way for the current and future company's needs.

Family aspects

Getzner endorses equal opportunities in all matters. This also includes offering home office and part-time work and promotion of parental leave.



4. Responsibility towards Partners and competitors

Getzner's actions are also oriented towards the success of its Partners. To this end, professional as well as comprehensible business relationships and ethical behaviour shall be promoted and maintained.

Getzner's competitive focus is always on the quality of its products and services. No measures are supported or tolerated which aim at or make possible a distortion of competition contrary to the statutory provisions. Getzner expects all employees and Partners to comply with the rules of fair competition.

Getzner only conducts business activities with reputable Partners complying with applicable laws and obtaining resources through legal sources.

Corruption / Bribery

The term 'corruption' is an umbrella term and basically includes any abuse of entrusted power / decision-making authority / a public office for a (personal) advantage or private benefit. Corruption is to be avoided - at all times, in all places. In this respect, Getzner undertakes to comply with the relevant statutory provisions, both at national and international level, and also requires this to its Partners.

A core issue of corruption is the bribery of public officials¹ or of persons with whom there is direct or indirect contact due to business relations. Bribery is the offering, promising or granting of unjustified advantages / benefits for the purpose of improperly influencing business decisions. Any form of bribery is prohibited without exception.

Getzner pays consultants and agents within a reasonable framework. Unjustified overpayment shall be strictly denied in order to exclude inadmissible benefits to third parties. Furthermore, all employees are prohibited from granting indirect monetary payments or other benefits (for example, to Partners or other third parties) if the circumstances indicate that these may be passed on in whole or in part, directly or indirectly, to a public official in order to influence an authority's action or to obtain an undue advantage or are granted to a person in the private sector to obtain an unlawful advantage.

The granting / acceptance of benefits shall always comply with certain general principles: among other things, the purpose of a donation shall always serve a legitimate business purpose, be transparent and be proportionate. Getzner's employees may find details in the Getzner Anti-Corruption Policy.

Taking of bribes

Employees of Getzner and persons or Partners engaged by Getzner may not accept or demand any unauthorised advantages / benefits.

¹ 'Public/government officials' are specifically civil servants and employees at all levels of an authority / institution of the executive, legislative or judiciary powers, candidates for political office, members of political parties, employees / representatives of companies which are state-owned or under state control, in particular state-owned companies, e.g. state railways such as ÖBB or DB, employees of public international organisations (e.g. UN, World Bank, EBRD, OECD etc.). Pay attention please: local definitions may be broader!



Invitations and gifts

Invitations to business-related meals or events may be made and also accepted limited to the usual extent. Details may be found in the Getzner Anti-Corruption Policy.

Employees' and Partners' invitations to sporting, cultural and artistic events ("pure entertainment events") are seen as critical. Furthermore, hospitality and invitations to travel shall always be checked with particular care. Please also refer to the Getzner Anti-Corruption Policy for details on this.

With regard to the giving and receiving of gifts, the above statements about the limits of appropriateness apply in principle. In particular, it shall be verified in each individual case that the effect associated with a gift does not lead to undue influence on the gift's recipient. The giving and receiving of gifts may only be voluntarily and never with the expectation of a consideration or any other kind of obligation. Offering or accepting money or benefits of monetary value is not permitted under any circumstances. Country-specific laws and practices shall be taken into account accordingly.

In any case, invitations and gifts shall always be prohibited if they may cause damage to Getzner's reputation or infringe Getzner's ethical and social values in any way.

Money laundering

Getzner and its Partners shall comply with the laws on the prevention of money laundering. To this regard, Getzner maintains business relationships exclusively with Partners having a serious reputation and whose financial situation is based on honest dealings. If there are any suspicions, a careful examination of the Partner shall be carried out. If an employee notices an unusual financial transaction (especially involving cash), a check shall be conducted by the finance or legal department.

Donations

Getzner is socially committed and accordingly supports various organisations and projects with donations of money or goods. These donations are of a voluntary nature, for a social purpose and in no way based on the expectation of a corresponding advantage or any other consideration in return.

Sponsorship

In addition, Getzner supports various clubs and projects of a sporting, cultural and artistic nature. Such support may be provided in cash or in kind or by means of services provision. Only a reputation-enhancing effect of the sponsorship is expected in return. This is linked to the fact that the supported associations and projects have a positive impact on Getzner's reputation.

Political contributions

Political parties shall not be supported. No donation or sponsorship measures shall be made to political parties in Germany or abroad, to party-affiliated or party-like organisations as well as to individual elected representatives or candidates for political office.

Lobbying

Getzner follows and complies with the statutory requirements on lobbying and requires the same from its Partners. Getzner's actions shall always be open and transparent. Unfair influence on politics and legislation shall be avoided under any circumstances.

Fair competition

The conduct of competitors companies is regulated by the relevant statutory provisions on unfair competition. Getzner is committed to the full implementation of these regulations in order to achieve fair competition. This obligation shall also be transferred by Getzner to all employees and Partners / engaged persons.

Restricting free and fair competition and infringing competition and antitrust laws is not a consistent behaviour with the corporate philosophy and culture.

For this reason, no measures shall be taken that may unfairly influence the free decision and behaviour of business

partners. As the market leader in some fields, Getzner shall comply, in some cases, with even stricter rules under applicable law. In this sense, Getzner shall not use its own market position to gain unjustified and competition-distorting advantages from this position. This is true at both national and intergovernmental levels. Getzner shall not even participate in any unlawful horizontal or vertical agreements regarding prices, quantities or markets or engage in any other type of illegal exchange of sensitive information. Getzner shall not even pay bribes to win a contract.

To ensure fair competition, all employees and Partners shall adhere to the following principles in particular:

- There shall be no agreements on business issues with competitors determining or influencing competitive behaviour. This specifically includes agreements / arrangements to fix prices or production capacities / quantities, sources of supply or the allocation of markets or customers.
- No unfair business practices shall be used or pressure exerted on middlemen to distribute products at a certain price.
- The submission of fake bids is prohibited and no arrangements / agreements may be made in this regard.

Economic sanctions and embargoes

As international trade is of great importance to Getzner, the relevant national and international trade control regulations shall be observed accordingly by all employees and Partners. Restrictions arising therefrom may relate to the type of product, country of origin or destination, or even to Partners themselves. In particular, Getzner shall comply with the applicable sanctions regulations and export control and embargo regulations. Circumvention by suppliers or Partners shall also be prevented. In order to prevent violations of these regulations and requirements, Getzner takes the necessary precautions in each case.

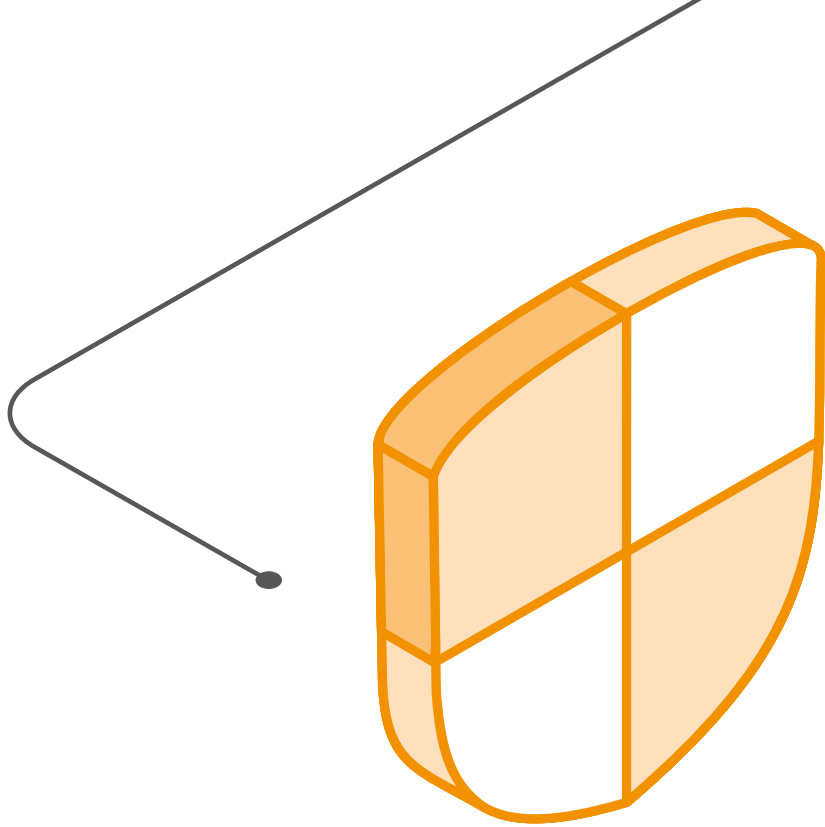

5. The Employees' Responsibility

The employees are the pride of Getzner and they represent the company to outside world. This makes the individual responsibility of all employees all the more important.

Confidentiality of information / protection of business secrets

Within the scope of their employment relationship, employees shall generally treat information concerning the company, Partners, customers, competitors or other employees confidentially. This also includes information outside their own area of activity. This applies, in particular, when explicit confidentiality agreements have been concluded. In this regard, any private use of confidential information, as well as disclosure to third parties, is prohibited. The confidentiality obligation shall continue to exist without restriction even after termination of the employment relationship. In addition, the relevant confidentiality provisions of the respective employment contracts shall apply.

Getzner shall take all necessary precautions to protect confidential information and especially business secrets²

from unauthorised access. Adequate protection should be achieved in particular by means of physical and electronic access restrictions and safeguards (disclosures only according to the 'need to know' principle), by agreeing on non-disclosure agreements (when exchanging confidential information with external Partners), by labelling documents and by raising employees' awareness on this topic.

External perception

The behaviour of its employees and managers defines the public perception of Getzner. It is important to note that, in addition to the real public sphere, this also includes any kind of digital environment (especially social media). Employees shall be aware that they may also be perceived as part of Getzner in their private lives and thus they represent Getzner. Therefore, they shall be encouraged and shall

² This information includes, for example, information on research and development processes, cooperation and acquisitions, major investments or divestments, strategies, customer data, material data, production facilities, formulas, master passwords, internal price lists, etc.

strive to uphold Getzner's reputation and standing at all times.

Getzner's dealings with employees, Partners and competitors are characterised by friendliness and proper respect. Cultural differences shall be taken into account accordingly.

Communication

Employees shall be aware that official statements to the media and communication through them are generally made by the Management Board or the Marketing Communications Department.

Conflicts of interest

In the framework of business activity, it is possible that employees may find themselves in situations where their personal or economic interests conflict or may conflict with Getzner's interests. Such conflicts per se shall not be deemed a misconduct yet - but dealing with the situation may be. In such situations, Getzner expects employees to act in Getzner's best interest. As such conflicts of interest cannot always be excluded, Getzner obliges employees to disclose such conflicts transparently.

Any actual or potential conflict of interest, even when it only appears that such a conflict may arise, shall be immediately and fully disclosed by the employee to the relevant supervisor without being requested to do so.

Conflicts of interest may arise in particular in connection with secondary employments, external positions or business activities. Accordingly, such activities shall always be approved by the respective manager and the HR Department. Economic engagements with competitors or other Partners of Getzner are not allowed.

Furthermore, when making business decisions, the idea of wanting to help a family member or acquaintance shall never be in the foreground. Business decisions are always made on the basis of objective criteria such as quality, price, reliability, technical standards, etc.

Protection of company property

Getzner employees shall make use of Getzner property and resources responsibly, carefully and appropriately, protecting them from loss, theft and misuse. Company property also includes Getzner's intellectual property - this ranges from individual expertise / know-how to proprietary patents. Intellectual property is a valuable asset for Getzner, which has a great value. It shall therefore be especially protected against unauthorised access by third parties.

Unless expressly permitted, company property shall only be used for business purposes and not for private purposes.

Information security and data protection

Data security and data protection are of great importance at Getzner. Accordingly, Getzner shall protect company data, customer, Partner and employee data against unjustified access, unauthorised and improper use, loss and premature destruction, using suitable and appropriate technical and organisational measures. This shall be done in compliance with the respective applicable law as well as the respective applicable internal policies and security regulations of Getzner.

Getzner is aware of the high sensitivity of the personal data entrusted by customers, Partners and employees. All employees shall therefore comply with the applicable data protection regulations and respect and observe, in particular, the full rights of the persons whose data they have to process. Personal data is only processed if this is permissible as per law or the consent of the data subject has been obtained.

6. Code of Conduct Implementation

This Code of Conduct shall be valid for all Getzner locations worldwide and shall be implemented in the appropriate form.

The Getzner Group includes all companies in which Getzner Werkstoffe GmbH has a direct or indirect interest of at least 50% or over which it exercises control in some other way.

Compliance obligation

Employees and managers shall comply with the Code of Conduct. Compliance is exemplified accordingly by the Management Board.

The provisions of the Code of Conduct shall also apply mutatis mutandis to Partners and all third parties involved by Getzner in any form (unless otherwise stipulated) and shall also be fully complied with by them.

Reporting misconduct

Partners and employees are equally encouraged to raise concerns, not tolerate detected misconduct and report it accordingly. A report shall be made in writing or verbally either to the supervisor or directly to the compliance officers or to the compliance email address compliance@getzner.com. Information about violations of laws or this Code of Conduct shall always be forwarded to a compliance officer.

Information on possible violations of laws or this Code of Conduct, in particular in the field of competition and anti-trust law, corruption, environmental protection, data protection, etc., may also be reported, also anonymously, via the online whistleblower system. Access to the system and further information on this topic are available online at www.getzner.com/compliance.

Protection of whistleblowers

All reports of misconduct within the meaning of this Code of Conduct and other statutory regulations shall be treated with equal care and confidentiality. In order to promote open and confident communication, it is expressly stated

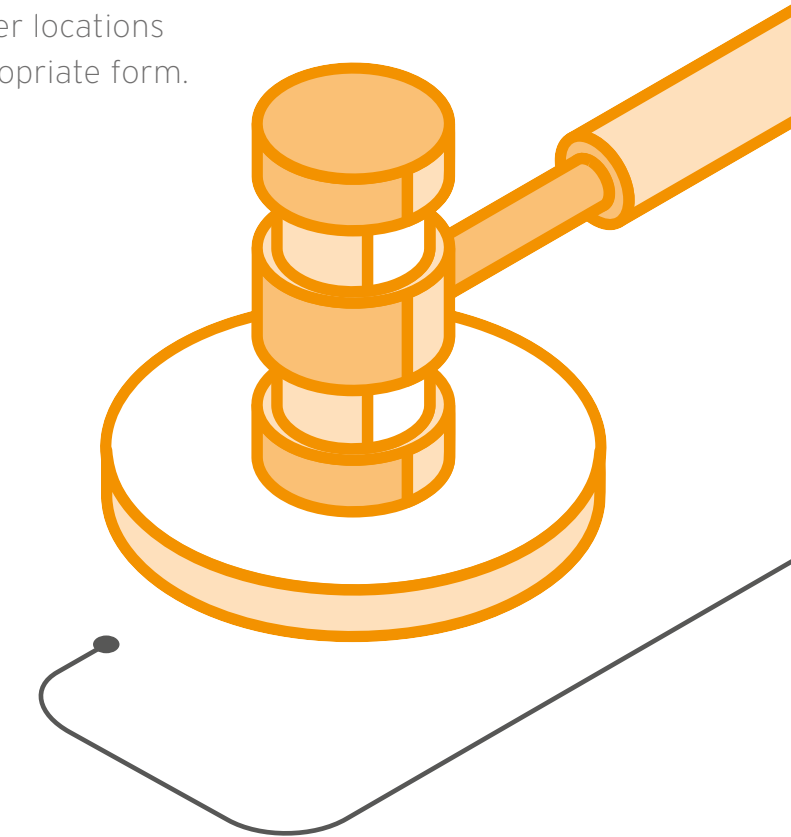

that whistleblowers who report violations of laws, Code of Conduct or other internal policies and regulations to the best of their knowledge and belief, and who are not (partly) responsible thereof, should not expect negative consequences of any kind. In particular, the transposition laws on the EU Whistleblower Directive shall be complied with accordingly. However, Getzner expressly reserves the right to take appropriate, possibly disciplinary, action against employees and other whistleblowers who bring false allegations, intentionally or through gross negligence.

Consequences of the misconduct

Violations shall result in both measures under labour law and disciplinary measures. Violations of the Code of Conduct provisions by Partners may lead to further consequences and legal implications such as termination of the cooperation / contract termination. Furthermore, it should be noted that violations of statutory requirements may also have civil and criminal consequences.



Contact persons

The compliance officer is Mr Florian Kiefer.

The deputy compliance officer is
Ms Katharina Pröll-Liegl.

The compliance body may be reached
at the following contact address:

compliance@getzner.com

Getzner whistleblower system:

www.getzner.com/compliance